

REV	MCO	DWN	DATE
B	20030751	SGL	28-JUN-99
C	20182803	SC	04-JAN-06

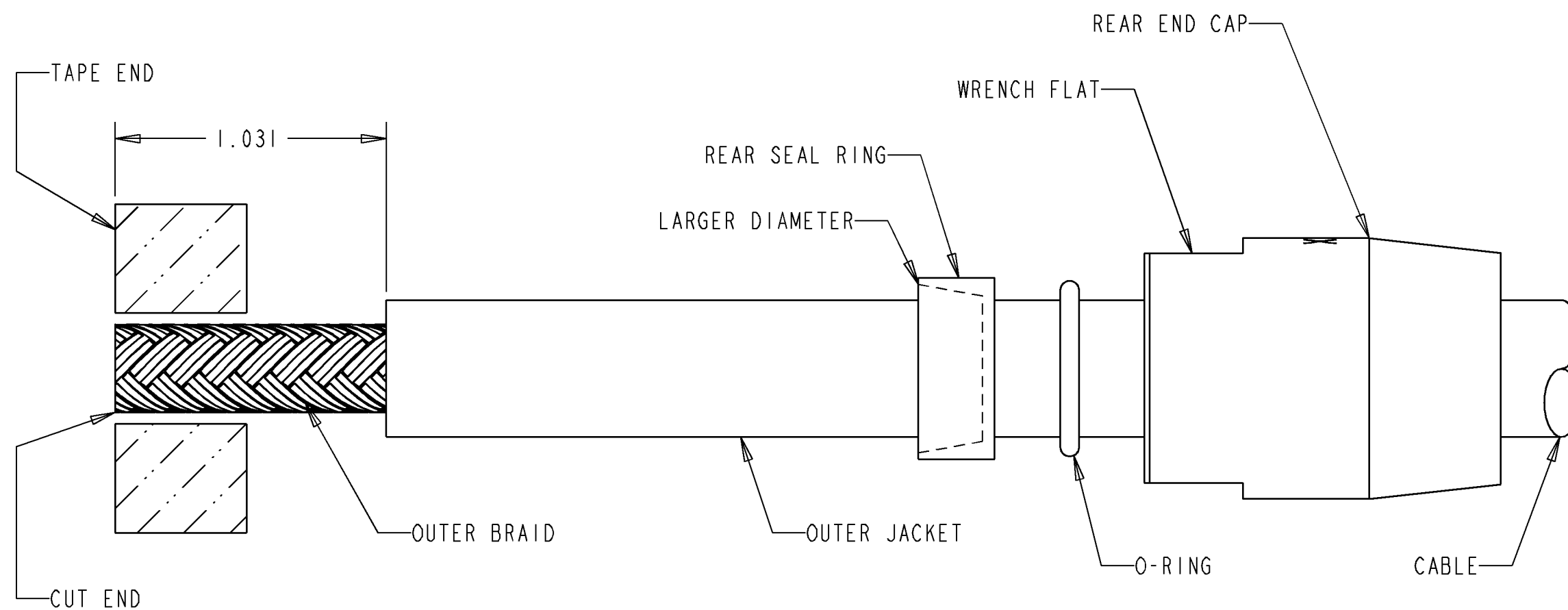

TERMINATION INSTRUCTIONS:

1. CUT CABLE END SQUARE. SLIDE END CAP AND REAR SEAL RING OVER THE OUTER JACKET OF CABLE. ORIENTATE REAR SEAL RING SO THAT THE LARGER DIAMETER IS FACING TOWARDS THE CUT END OF CABLE AS SHOWN BY HIDDEN LINE.
2. REMOVE OUTER JACKET TO 1.031" DIMENSION AS SHOWN. WRAP THE END OF THE OUTER BRAID WITH TAPE TO RETAIN THE BRAID FOR ASSEMBLING THE THREADED INSERT.

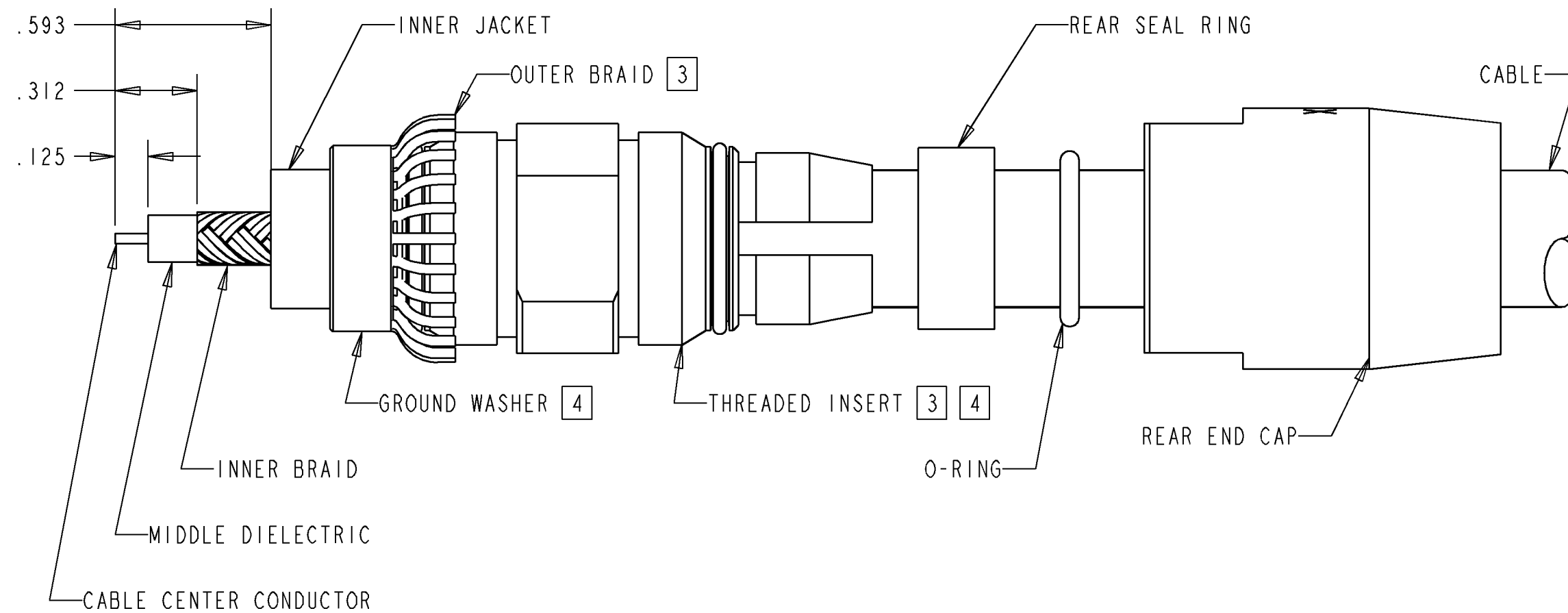

- [3] PLACE THREADED INSERT OVER THE OUTER JACKET OF CABLE AND REMOVE TAPE. PULL BACK OUTER BRAID OVER THREADED INSERT.
- [4] PLACE GROUND WASHER OVER THE OUTER BRAID AND SEAT AGAINST THE THREADED INSERT AND PRESS.
5. REMOVE INNER JACKET AND INNER BRAID TO .312" DIMENSION. REMOVE INNER JACKET AN ADDITIONAL .281". DO NOT NICK BRAID.
6. REMOVE MIDDLE DIELECTRIC TO .125" DIMENSION TO EXPOSE CABLE CENTER CONDUCTOR. DO NOT NICK OR UNRAVEL CENTER CONDUCTOR.
7. CRIMP OR REPLACE REMAINING PARTS AND SCREW DOWN TIGHTLY.

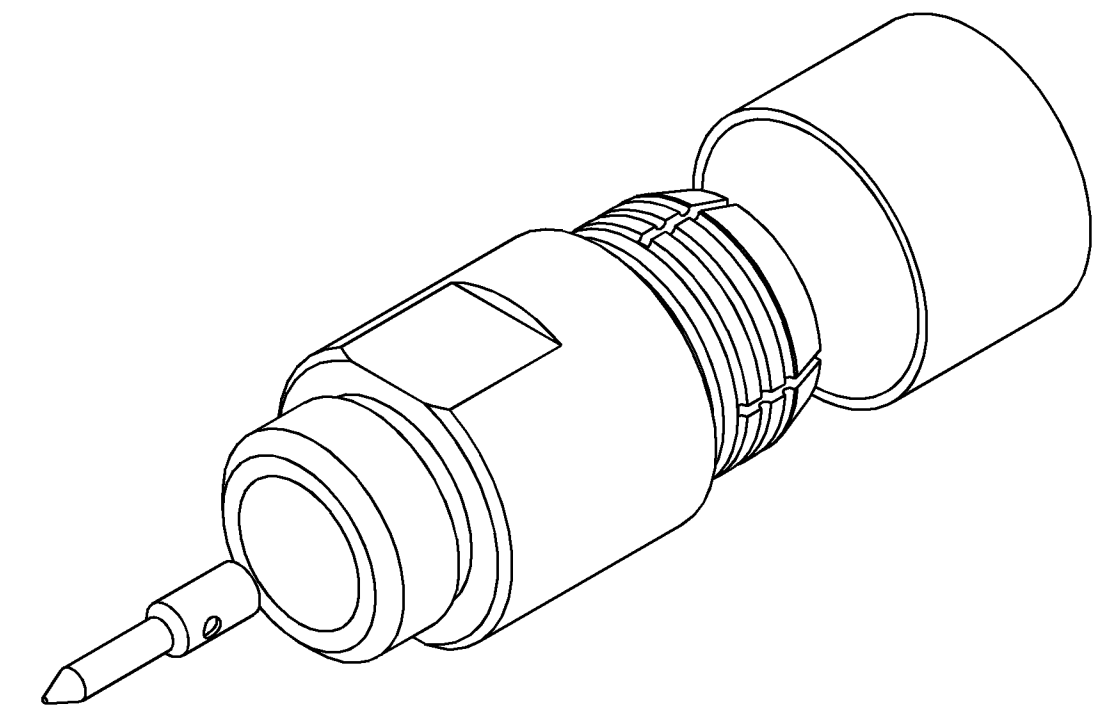

NOTES:

1. UNSCREW FRONT CONNECTOR BODY ASSEMBLY FROM REAR ASSEMBLY.
2. REMOVE OUTER INSULATOR.
3. UNSCREW FRONT CENTER CONDUCTOR SHELL FROM REAR SLEEVE.
4. REPLACE PARTS AS REQUIRED FOLLOWING TERMINATION INSTRUCTIONS.
5. SCREW CENTER CONDUCTOR SHELL AND SLEEVE TOGETHER.
6. REPLACE OUTER INSULATOR.
7. SCREW FRONT CONNECTOR BODY ASSEMBLY AND REAR ASSEMBLY TOGETHER.

TRK-RP	Ø .520
TRK-RD	Ø .410
TRK-RC	Ø .520
TRK-RA	Ø .475
TRK-RB	Ø .360
<b>CATALOG NUMBER</b>	<b>CABLE SIZE/DIA</b>

INFORMATION ON THIS DOCUMENT IS PROPRIETARY TO ADC AND SHALL NOT BE USED, COPIED, REPRODUCED OR DISCLOSED IN WHOLE OR IN PART WITHOUT WRITTEN CONSENT OF ADC.

ALL DIMS AND TOLERANCES .XX:±N/A ARE INCHES UNLESS .XXX:±N/A OTHERWISE SPECIFIED ANGULAR:±N/A

DO NOT SCALE DRAWING

ENGR: MIKE FOLLINGSTAD  
DWN: M. ANIS KHEMAKHEM

TITLE DWG, INST. REPAIR KIT REAR, UNIVERSAL

DRAWING NUMBER 1020879

SHT. 1 OF 1

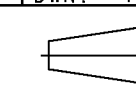
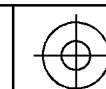

DIMENSIONS IN INCHES  
THIRD ANGLE PROJECTION